



fibo Collect

A business opportunity in self-service batching technology

Sustainable concrete solutions



A welcome message from the CEO

Hello and welcome to fibo intercon. My name is Henrik Jeppesen, and I am delighted that you have taken the time to learn about the fibo Collect business opportunity.

We are proud to develop high-quality mobile batching plants that are renowned in the industry for being customised and extremely durable. Many of our machines have proven to last for over 20 years.

Our focus has been on investing into the future of sustainable concrete and batching technology — we always try to make the solution green and supportive of a circular economy.

Our philosophy towards product development is simple: innovation, digitalisation and sustainability.

Sincerely,

Henrik B. Jeppesen, CEO
fibo intercon

Henrik B. Jeppesen



“

What started as an internal sentence, “easy-to-clean-green-machine”, has become our overall philosophy in product development.

fibo Collect has the power to help end-users save both money and time whilst generating a great return on investment for our customers.

Henrik B. Jeppesen

”

What's inside

| | |
|---------------------------------------|-----------|
| See fibo in action | 6 |
| Overviews of the product range | 8 |
| Model specifications | 14 |
| Optional extras | 21 |
| Digital innovation | 23 |
| Green thinking | 24 |
| Customer stories | 26 |
| Business support | 30 |
| Service and support | 31 |

[CONTACT US](#)



Enable your community with concrete, mortar and screed 24/7

- ✓ Give contractors and individuals in your community the opportunity to buy competitively priced, quality concrete, mortar and screed
- ✓ Supply your customers without creating waste and spill
- ✓ Attract more customers with a new unique selling point
- ✓ Offer customers a more convenient solution
- ✓ Reduce overall waste in the production process
- ✓ Diversify your product offering
- ✓ Help customers get results by offering the same high quality product every time



**Consumer friendly,
self-service batching plant.
Easy to maintain with minimal
space requirements.**



See fibo in action





Define your needs

These are our standard solutions —
enhance them to watch your needs.

FS range

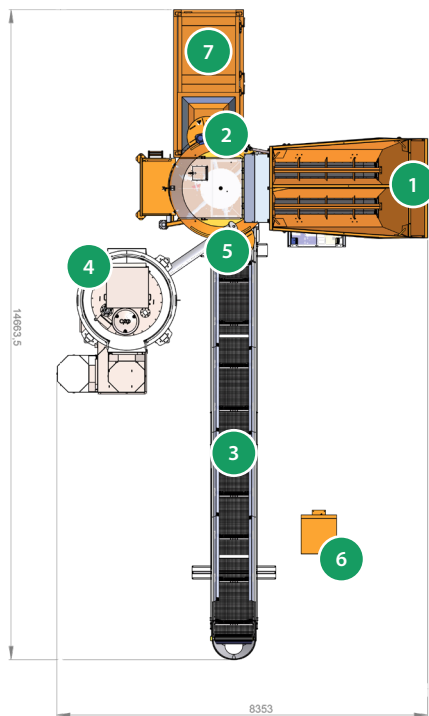

F range

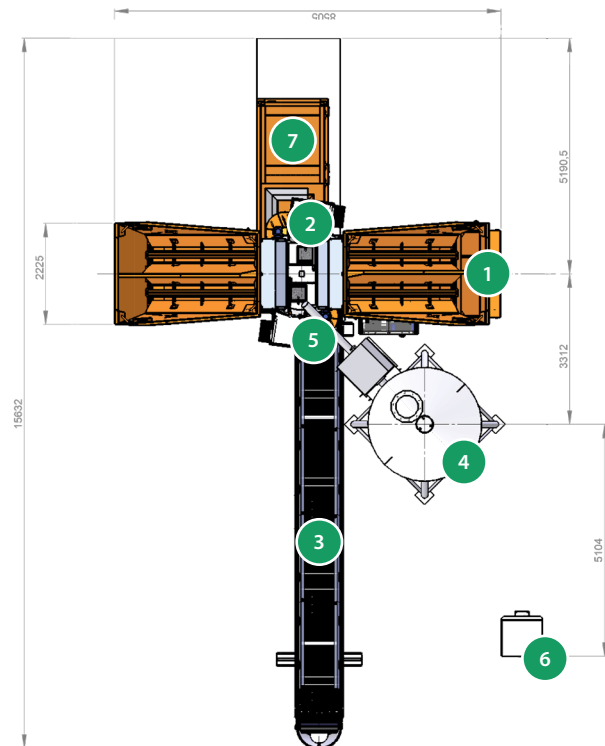

FS / F range key

- 1 Aggregate hoppers
- 2 Pan mixer
- 3 Conveyor belt
- 4 Cement silo
- 5 Cement auger
- 6 Payment
See options on page 11
- 7 Washout water recycling

Configure your requirements

Increase the aggregate capacity of your solution to reduce labour cost.



FP Inliner range

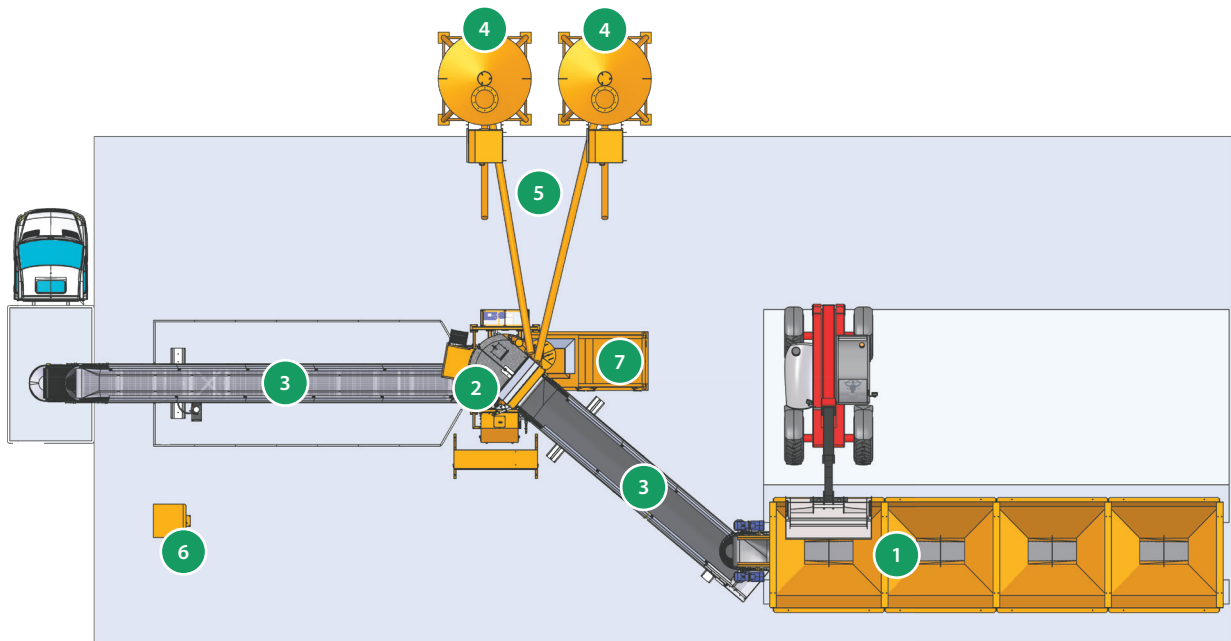

FP Inliner range key

- 1 Inliner / aggregate hoppers
- 2 Pan mixer
- 3 Conveyor belt
- 4 Cement silo
- 5 Cement auger
- 6 Payment
See options on page 11
- 7 Washout water recycling

Create a one-stop shop

Up to 10 large aggregate hoppers. Expand your supply offering by selling concrete, mortar, screed and aggregates.

Extended range

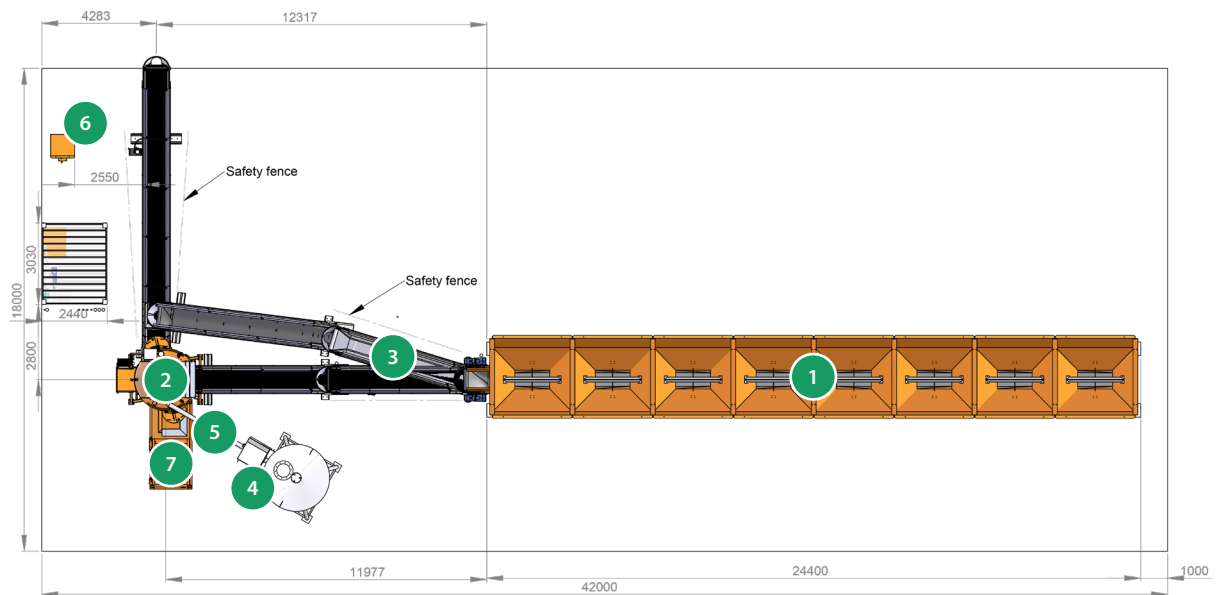

Extended range key

- 1 Inliner / aggregate hoppers
- 2 Pan mixer
- 3 Conveyor belt
- 4 Cement silo
- 5 Cement auger
- 6 Payment
See options on page 11
- 7 Washout water recycling

Features

In addition to a basic solution, there are numerous options and extra features to adapt to your work environment and customer requests.

Payment



Payment terminal. RFID token.

Issue RFID tokens to customers so they can collect from the **fibo** payment terminal:

- Place an order on screen.
- Scan your RFID token.
- Start batching your requested order.



Payment terminal. Pay on the go (credit card).

Pay and retrieve your concrete at the “**fibo** payment terminal”:

- Place an order on the screen.
- Pay by credit card.
- Start batching your requested order.



Point of sale (POS). In-store bar code creation.

Pay at the counter and receive a barcode for self-service concrete collection.

- Pay for your order in-store and receive a barcode.
- Scan your barcode at the terminal.
- Start batching your requested order.

Cleaning



Self cleaning mixer. Maintain your machine.

An automated washing system cleans the pan mixer immediately after a batch is delivered or at a time of your choice. Everyone deserves a clean mix – both you and your customers.

Waste

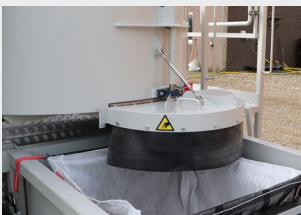

Waste recycling unit. Reduce water cost and earn green money.

Our recycling unit separates the washout from the water and reconditions the water for use in another concrete batch. **fibo** enables a cost-efficient and environmental production.

**Expand your supply offering
by selling concrete, mortar,
screed and aggregates.**

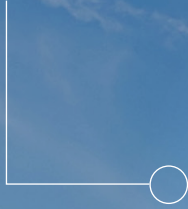



FS model specifications

The FS model is an ideal model where space is scarce and where the breadth of quality mixes required is limited – 1 hopper for sand and 1 hopper for gravel.



| | FS 1200 | FS 1800 |
|---|---------------------|---------------------|
| Volume (Gross / Net) L | 1,200 / 800 | 1,800 / 1,100 |
| Capacity m ³ per hour | 10 - 16 | 20 - 30 |
| Motor kW | 18.5 | 30 |
| Sound pressure level dB (A) | 77.7 | 77.7 |
| Mixing arms: side scrapers No | 6:1 | 6:1 |
| Load cells Kg | 3 x 5,000 | 3 x 5,000 |
| Weighing accuracy % | +/- 0.5 | +/- 0.5 |
| Dosing accuracy % | +/- 3 | +/- 3 |
| Recipes No | 60 | 60 |
| Aggregate hopper m ³ | 2 x 2.4 | 2 x 2.4 |
| Water tank L | 500 | 500 |
| Dimension (W x H x L) m | 2.3 x 2.5 x 5.3 | 2.3 x 2.5 x 5.9 |
| Weight Kg | 4,000 | 6,500 |
| Power Voltage | 3 x 400V N PE 50Hz | 3 x 400V N PE 50Hz |
| A/KVA | 50 / 35 | 80 / 55 |
| Socket inlet | CEE 63A 5P 230/400V | CEE 63A 5P 230/400V |
| Generator KVA | 65 | 100 |

F model specifications

The F model features 4 hoppers and allows for a wide variety of high-quality concretes and mortars to be produced.

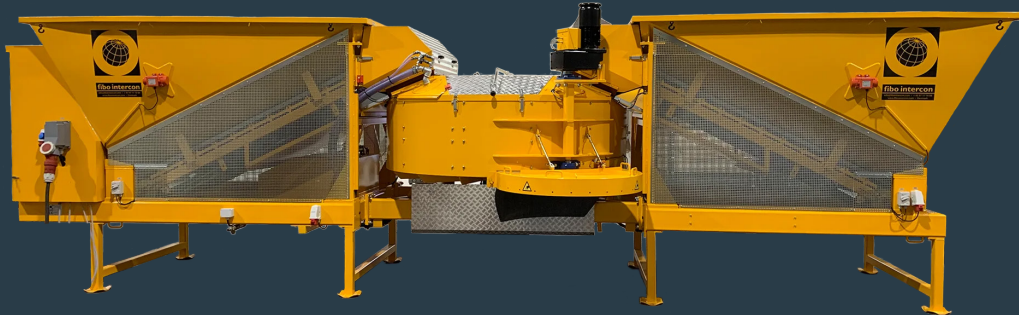

| | F 1200 | F 1800 |
|--|---------------------|---------------------|
| Volume (Gross / Net) L | 1,200 / 800 | 1800 / 1,100 |
| Capacity m³ per hour | 10 - 16 | 20 - 30 |
| Motor kW | 18.5 | 30 |
| Sound pressure level dB (A) | 77.7 | 77.7 |
| Mixing arms: side scrapers No | 6:1 | 6:1 |
| Load cells Kg | 3 x 5,000 | 3 x 5,000 |
| Weighing accuracy % | +/- 0.5 | +/- 0.5 |
| Dosing accuracy % | +/- 3 | +/- 3 |
| Recipes No | 60 | 60 |
| Aggregate hopper m³ | 4 x 2.4 | 4 x 2.4 |
| Water tank L | 500 | 500 |
| Dimension (W x H x L) m | 2.3 x 2.61 x 8.7 | 2.4 x 2.61 x 8.9 |
| Weight Kg | 6,500 | 9,500 |
| Power Voltage | 3 x 400V N PE 50Hz | 3 x 400V N PE 50Hz |
| A/KVA | 50 / 35 | 80 / 55 |
| Socket inlet | CEE 63A 5P 230/400V | CEE 63A 5P 230/400V |
| Generator KVA | 65 | 100 |

FP model specifications

The FP-model is a stand-alone batching plant that we combine with any number of hoppers and options. All batching plant features **fibo** has to offer are available.



| | FP 1200 | FP 1800 |
|---|---------------------|---------------------|
| Volume (Gross / Net) L | 1,200 / 800 | 1,800 / 1,100 |
| Capacity m ³ per hour | 10 - 16 | 20 - 30 |
| Motor kW | 18.5 | 30 |
| Sound pressure level dB (A) | 77.7 | 77.7 |
| Mixing arms: side scrapers No | 6:1 | 6:1 |
| Load cells Kg | 3 x 5,000 | 3 x 5,000 |
| Weighing accuracy % | +/- 0.5 | +/- 0.5 |
| Dosing accuracy % | +/- 3 | +/- 3 |
| Recipes No | 60 | 60 |
| Water tank L | 500 | 500 |
| Dimension (W x H x L) m | 2.1 x 2.3 x 3.7 | 2.3 x 2.5 x 4.2 |
| Weight Kg | 3,000 | 4,500 |
| Power Voltage | 3 x 400V N PE 50Hz | 3 x 400V N PE 50Hz |
| A/KVA | 50 / 35 | 80 / 55 |
| Socket inlet | CEE 63A 5P 230/400V | CEE 63A 5P 230/400V |
| Generator KVA | 65 | 100 |

Inliner specifications

The inliner solution is ideal for businesses with available space and a diverse range of customer requirements. Reduce labour costs whilst expanding into aggregate sales.



| | | | | | | | |
|---|------|------|------|------|------|------|------|
| Volume per box m ³ | 10 | 10 | 10 | 15 | 15 | 25 | 25 |
| Boxes pcs | 4 | 6 | 8 | 3 | 6 | 3 | 6 |
| Maximum capacity m ³ /batch | 1 | 1 | 1 | 1 | 1 | 1 | 1 |
| Width m | 2.44 | 2.44 | 2.44 | 2.32 | 2.32 | 2.32 | 2.32 |
| Height (transportation) m | 2.95 | 2.95 | 2.95 | 2.95 | 2.95 | 2.95 | 2.95 |
| Length weighing belt m | 11.5 | 22.5 | 23.5 | 11.5 | 22.5 | 11.5 | 22.5 |
| Weighing cells pcs | 4 | 8 | 8 | 4 | 8 | 4 | 8 |

Belt conveyors specifications

Choosing the right conveyor for your customers is essential.
How high and low do you need to go?

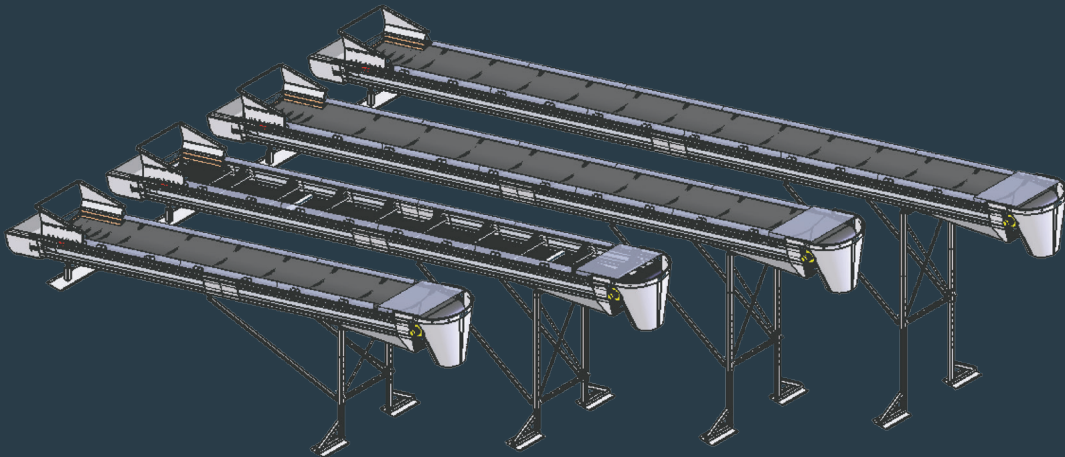

| | 0.8m | 1.0m |
|--------------------------|---------------|---------------|
| Length m | 8 - 12 | 8 - 14 |
| Outlet height m | Adjustable | Adjustable |
| Belt speed m/sec | 1.6 | 1.6 |
| Belt rollers type | PEH and steel | PEH and steel |
| Belt scrapers pcs | 2 | 2 |
| Drum motor kW | 4 | 7.5 |
| Inlet funnel pcs | 1 | 1 |
| Outlet funnel pcs | 1 | 1 |

Hydraulic belt conveyor specifications

Enhance your conveyor with automation.

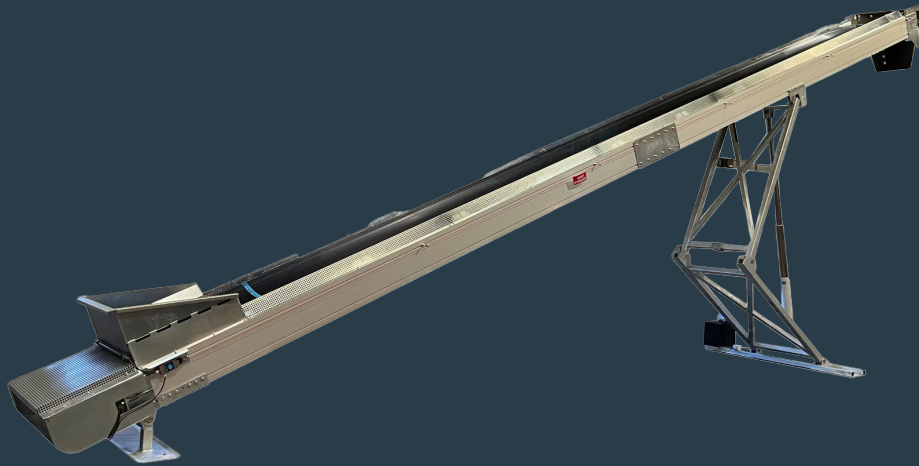

1.0m

| | |
|--------------------------------|---------------|
| Length m | 10, 12 or 14 |
| Outlet height minimum m | 1.4 |
| Outlet height maximum m | 4.6 |
| Belt speed m/sec | 1.6 |
| Belt rollers type | PEH and steel |
| Scrapers pcs | 2 |
| Drum motor kW | 4 |
| Inlet funnel pcs | 1 |
| Outlet funnel pcs | 1 |



Most common optional extras

Here are some of the most common **fibro** collect options ordered by our existing customers

1 Customized color

You can choose the color for your plant, so it fits your other equipment.

2 Vibrator

Vibrator MVE 100/3 for vibrating sand out of the hopper, with cabling and switch. Required placement on the left or right hopper side. Makes sure all aggregates in the hopper used.

3 Wattmeter

Measuring motor load resistance may allow concrete viscosity measuring. Consequential processes can be automated in the control system.

4 Extended hopper sides

Increase silo capacity by 60 %. The enlarged silo sides add 1.5 m³ to each hopper, so the total volume for each hopper is 3.9 m³.

5 Additive pump and flow meter

High-quality time-based dosing pump with electro magnetic flow meter.

6 Insulation/Winter package

Liquid supply lines are equipped with trace heating tape and additional insulation. The cabinet for additive and high-pressure cleaner pumps is fitted with a radiant heater.

7 Water heater

Electric heating in the water tank for frost protection. Complete with thermostat and switch.

9



Dust filter for the mixer to reduce cement dust in the environment

8

8 Temperature sensor for the water tank

Sensor for measuring the water temperature in the tank.

9

9 Dust filter for the mixer

Filter to reduce cement dust in the environment during the dosing process.

10

10 Water protection cover

Removable cover made of heavy-duty PVC to protect aggregates from the elements. Easy and quick deployment with a manual winch.

11

11 Fibre dispenser

Automated synthetic fibre dispenser.

Continuous improvement through digital innovation

At fibo intercon, innovation never stands still. With sustainability as an important part of our DNA, we tirelessly develop technologies and solutions, aimed at reducing the carbon footprint in construction. At the same time, we put customer value and knowledge sharing at the centre of our developments.

Latest innovations



Cloud based integration

fibo cloud-based resource and data management system.

- Online accessible plants
- Monitoring of production and productivity
- Recipe and pricing management
- Aggregate and cement management
- Possibility for using the terminal screen as advertising space
- Remote service and support



fibo Link

- Online where-ever, when-ever
- Remote supervision
- Monitoring of production and deadlines away-from-sight
- Order aggregate / materials based on status alarms away-from-sight
- Production and sales data for your fibo collect



fibo Academy

fibo Academy is a learning platform about your system — from set up to programming

- Sharing concrete knowledge and beyond
- Maintenance and troubleshooting
- Programming of recipes, pricing, etc



CO2 calculations

Is the carbon footprint a deciding factor for your fibo collect

- The innovative but straightforward self-service approach ensures quality, accuracy and sustainability
- Talk to fibo for location based CO₂ calculations



fibo Collect and Aggregates

- Dosing of aggregates for single sale



fibo Collect - Customized dosing

- End-user differentiated dosing of **accelerators** for faster curing
- End-user differentiated dosing of **retarders** for delayed curing
- End-user differentiated dosing of **fibers** for increased strength

The innovative but straightforward self-service approach ensures quality, accuracy and sustainability.



Green thinking

fibo intercon is dedicated to carbon reduction and sustainability in concrete production. We have tools to help you reduce your carbon footprint and improve your sustainability.

The tools include:

- Concrete waste recycling
- Carbon reduction calculator
- CO₂ and pollution reduction
- Cement dust filter
- Self-cleaning pan mixer
- More circular economy: Less waste, less water use, fewer production failures, less workforce and reduced overflow production
- More bottom-line green earnings



Concrete
Circular
Economy

Concrete
Waste
Recycling

Carbon
Reduction



“

We are proud of our technology and innovation. It is today's state of the art in concrete production. What started as an internal sentence, "easy-to-clean-green-machine", has become our overall philosophy in product development: Make it automatic, have a cleaner production, reduce failures and setbacks and always try to make the solution green and circular.

Henrik B. Jeppesen, CEO
fibo intercon

”





Customer stories

Listen to what some of our customers have to say about **fibo** collect.

THORNCLIFFE
BUILDING SUPPLIES LTD.

Thorncliffe Building Supplies Ltd

LIVE 02/23

Builder's merchant, North Wales

The UK's first ever **fibo** collect installation at an independent local builders merchants in North Wales.

“ The process is so simple. The customer comes to our trade counter as normal, they tell us the mix and quantity they want, we produce their bar code. Within about 5 minutes can have the exact product they require.

We are already looking at expanding this it into our delivery network and rolling it out to the rest of our sites across North Wales.

Tim Harper
Managing Director

[WATCH ONLINE](#)



ATDV

ADTV 

Construction, France

LIVE 10/22

A **fibo** collect plant for the local community in the Western part of France.

“ The **fibo** collect concrete self-service plant is the solution for customers who want to buy dry or wet concrete from Monday to Sunday.

Thanks to its automatic water washing system, we have excellent quality concrete and mortar without gravel residues. The automatic mixer washing system frees us from the need to clean at the end of the day or even during hot weather.

The **fibo** collect self-service plant is an environmentally friendly solution for professionals and private individuals.

Emmanuel Rochteau
SAS DBPE



Click below to see our latest **fibo** collect videos online.

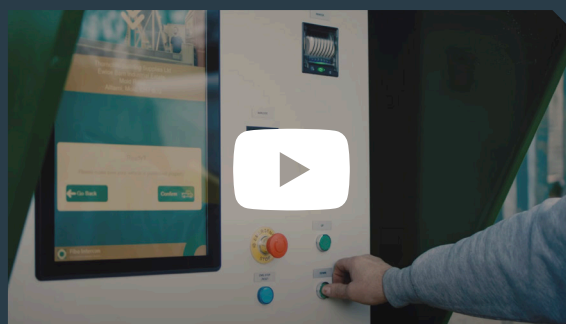

fibro intercon

Concrete solutions for the future

fibro intercon is a leading partner and supplier to the global concrete industry. We manufacture and deliver both mobile and semi-mobile concrete batching plants.

Our vast experience and innovational approach drive continuous improvements and change. We aim to support your business by delivering world-class concrete solutions that not only raises your productivity but also reduces your carbon footprint.

Whatever the challenge – and wherever in the world – we bring on knowledge, technology and new perspectives to the table and meet your needs from one end to the other.



1978

A/S **fibro** is divided into independent divisions. Production and installation of global concrete plants becomes the main line of business.

2019

Our vast experience and innovational approach drive continuous improvements and solutions development.

2022

fibro collect product launch.

1935

The company starts as a repair workshop associated with Fiskbaek Briketfabrik.

2003

fibro maskiner a/s acquires the Danish company Inter Con which is a reputable supplier of mobile batching solutions.

2020

fibro intercon A/S is one of the most important providers of segment-based mobile batching solutions globally.



Knowledge and technology that grows your business

- Danish design and quality
- Built-to-last technology ensures high return on investment
- Reduction of your carbon footprint (average of 10%)
- Recycling of waste with concrete waste management system
- Easy installation and low maintenance costs
- Global service and support

2023

World of Concrete disruptive innovation award.

2023

Danish SME digitalisation award.

fibro intercon has been in existence for more than 70 years. It started out as a repair workshop, but for the last 40 years the company has been developing and manufacturing different types of machinery.



fibo Business Support

helping customers get a return on investment

fibo has a global network of partners to ensure that customers can get hands on support in developing their business case and calculating the return on investment.

Some of the things we offer

- ✓ Customised 3D drawings
- ✓ ROI Calculation including:
 - Cost breakdown
 - Cashflow
 - Management report
- ✓ Support with go to market strategy and planning





Service and support

Documentation, warranty and control

We take pride in supporting you from the initial plant set-up to helping you with disposal at the end of the plant's life. A well-maintained **fibo** collect batching plant will give you a service life between 15-20 years.

Your service benefits

- Pre-delivery technical inspection and hands training with our team in Denmark
- Experienced support at your site
- **fibo** Technical Academy, including technical service, videos and downloads
- Cloud-based connection to your plant for fast troubleshooting
- Preventive maintenance online support

Getting started

fibo has a global network of approved partners that allow us to service customers all over the world. Get in touch with your local **fib**o contact using the details below.



fibo intercon

fibo intercon
Herningvej 4
Videbæk
Denmark

+45 97 17 16 66
info@fibointercon.com
www.fibointercon.com



ÅRETS DIGITALE
SMV:OMSTILLING